

Application for development approval

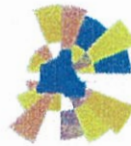

SHIRE OF
MERREDIN
INSPIRING THE WHEATBELT

Owner details		
Name: Delacour Pty + Swiss Pty T/A Merredin Tourist Park		
ABN (if applicable): 976 9844 2973		
Address: 2006 Stie N Merredin		
		Postcode:
Phone: Work:	Fax:	Email: parkavenue@westnet.com.au
Home:		
Mobile: 0409119255		
Contact person for correspondence: Frank Delarotte		
Signature:		Date: 21-8-20
Signature:		Date:
<p><small>The signature of the owner(s) is required on all applications. This application will not proceed without that signature. For the purposes of signing this application an owner includes the persons referred to in the Planning and Development (Local Planning Schemes) Regulations 2015 Schedule 2 clause 62 (2).</small></p>		
Applicant details (if different from owner)		
Name: HOLTRO MODULAR PTY LTD.		
Address: PO BOX 4		
BASSENDIAN WA		Postcode: 6934
Phone: Work:	Fax:	Email: troy@holtro.com.au
Home:		
Mobile: 0420 777 542		
Contact person for correspondence: TROY MILLER		
<p>The information and plans provided with this application may be made available by the local government for public viewing in connection with the application. <input type="checkbox"/> Yes <input type="checkbox"/> No</p>		

Signature: 	Date: 25/08/2020
---	------------------

Property details		
Lot No:	House/Street No:	Location No:
Diagram or Plan No:	Certificate of Title Vol. No:	Folio:
Title encumbrances (e.g. easements, restrictive covenants):		
Street Name: 2 OATS STREET	Suburb: MEREDIN	
Nearest street intersection: GREAT EASTERN HWY		

Proposed development	
Nature of Development	<input checked="" type="checkbox"/> Works <input type="checkbox"/> Use <input type="checkbox"/> Works and use
Is an exemption from development claimed for part of the development?	
<input type="checkbox"/> Yes <input checked="" type="checkbox"/> No	
If yes, is the exemption for	<input type="checkbox"/> Works <input type="checkbox"/> Use
Description of proposed works and/or land use:	UAT TOILET/BATHROOM
Description of exemption claimed (if relevant):	
Nature of any existing buildings and/or land use:	TOURISM
Approximate cost of proposed development:	\$25,000.00
Estimated time of completion:	1ST DEC 2020

OFFICE USE ONLY



PRELIMINARY DESIGN

PROJECT ADDRESS:

MERREDIN TOURIST PARK
2 OATS STREET
MERREDIN, WA



Copyright © 2020 Holtro Modular Pty Ltd

All rights reserved. No part of this design may be reproduced or used in any matter without written permission of the copyright owner.

DISABLED TOILET BLOCK

COVER SHEET

SCALE (A3) DRAWN A0
CW

Telephone: 0420 777 542
e-mail: troy@holtro.com.au

ABN: 85 634 505 169
BRN: 103165



PRELIMINARY DESIGN

PROJECT ADDRESS:

**MERREDIN TOURIST PARK
2 OATS STREET
MERREDIN, WA**



Copyright © 2020 Holtro Modular Pty Ltd

All rights reserved. No part of this design may be reproduced or used in any matter without written permission of the copyright owner.

**DISABLED TOILET BLOCK
COVER SHEET**

SCALE (A3) DRAWN A0
CW

Telephone: 0420 777 542
e-mail: troy@holtro.com.au

ABN: 85 634 505 169
BRN: 103165

STRUCTURAL CERTIFICATION BY:
 JOE ARENA CPEng BE MIEAust NPER 24918
 (CIVIL/STRUCTURAL)
 M: 0437 177 817
 E: joe.arena@arenaclauson.com.au



SIGNED: *Joe Arena CPEng*

DATE: 07/08/2020

REF: J20119

PROJECT:

VENDOR SUPPLIED TIMBER TRUSSES TO MEET WIND CLASS 'N2' LOADING

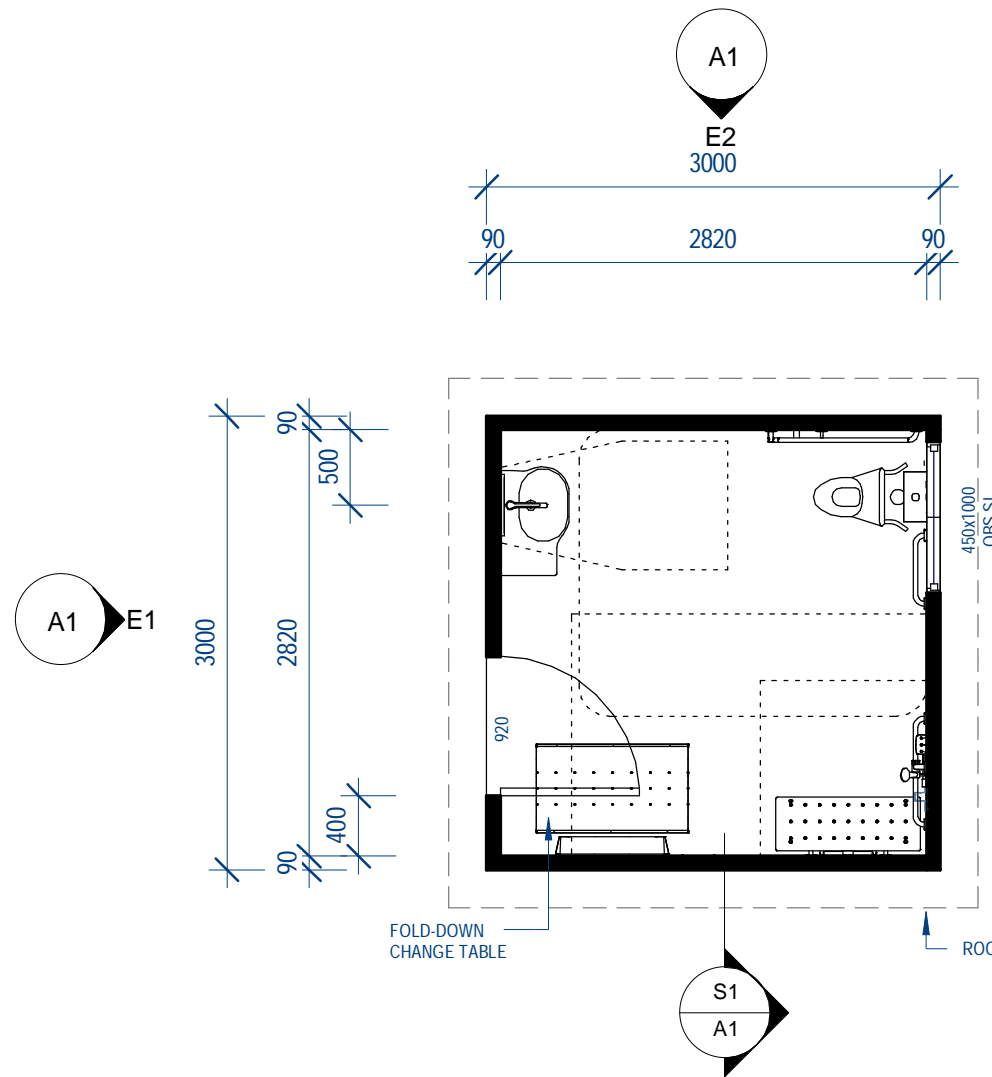

1 - Floor Plan
1 : 50

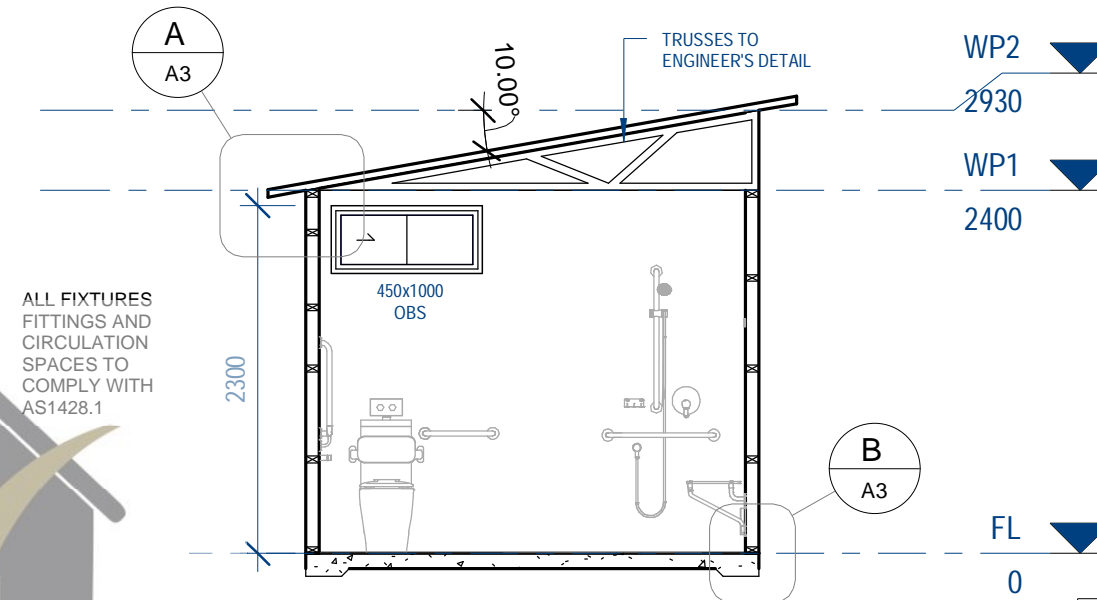

Section 1
1 : 50

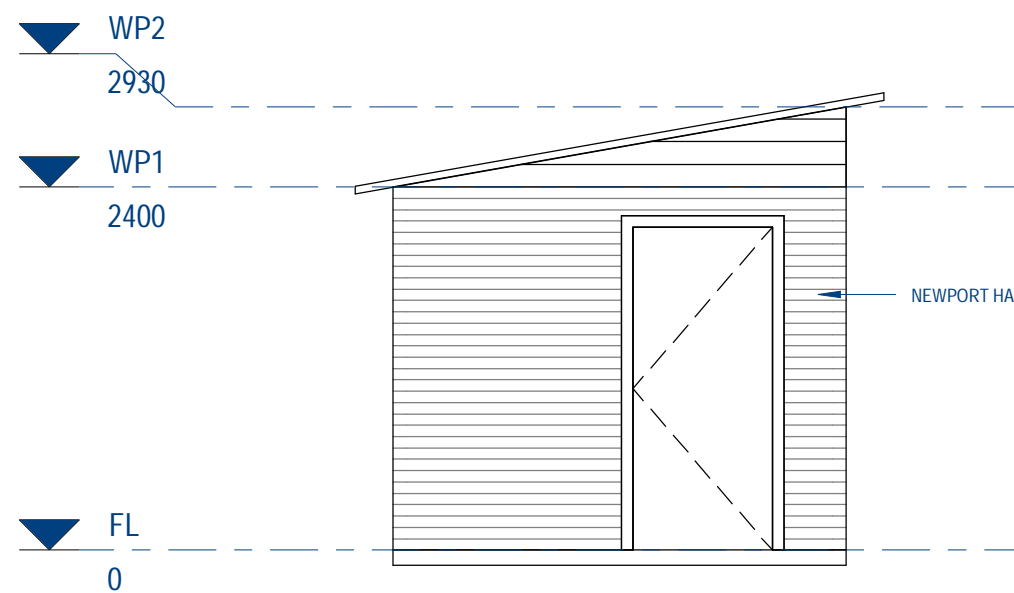

Elevation 1
1 : 50

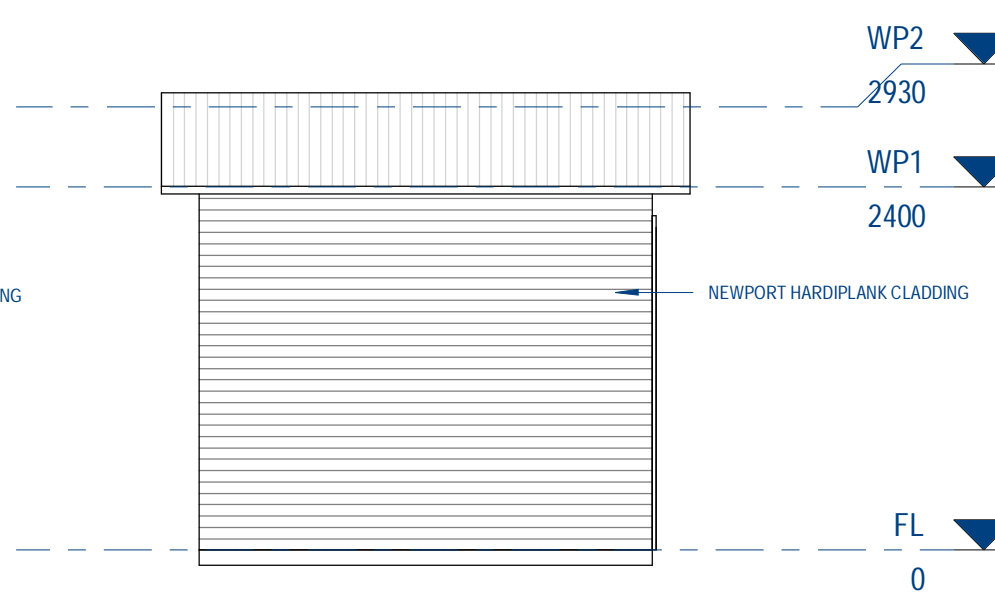

Elevation 2
1 : 50

NOTES:
FURNITURE FOR ILLUSTRATION PURPOSES ONLY.

PRELIMINARY DESIGN

NO.	DESCRIPTION	DATE
A	ISSUED FOR REVIEW	26/06/2020
B	ISSUED FOR REVIEW	29/06/2020
C	ISSUED FOR REVIEW	06/07/2020



Copyright © 2020 Holtro Modular Pty Ltd

All rights reserved. No part of this design may be reproduced or used in any matter without written permission of the copyright owner.

DISABLED TOILET BLOCK

MERREDIN TOURIST PARK

PLAN, ELEVATIONS & SECTION

SCALE (A3) 1 : 50 DRAWN CW A1 C

Telephone: 0420 777 542
e-mail: troy@holtro.com.au

ABN: 85 634 505 169
BRN: 103165

STRUCTURAL CERTIFICATION BY: JOE ARENA CPEng BE MIEAust NPER 24918 (CIVIL/STRUCTURAL) M: 0437 177 817 E: joe.arena@arenaclauson.com.au	 ARENA CLAUSON ENGINEERING GROUP PO BOX 435 MOUNT HAWTHORN WA 6915
SIGNED: <i>Joe Arena CPEng</i>	REF: J20119
DATE: 07/08/2020	PROJECT:

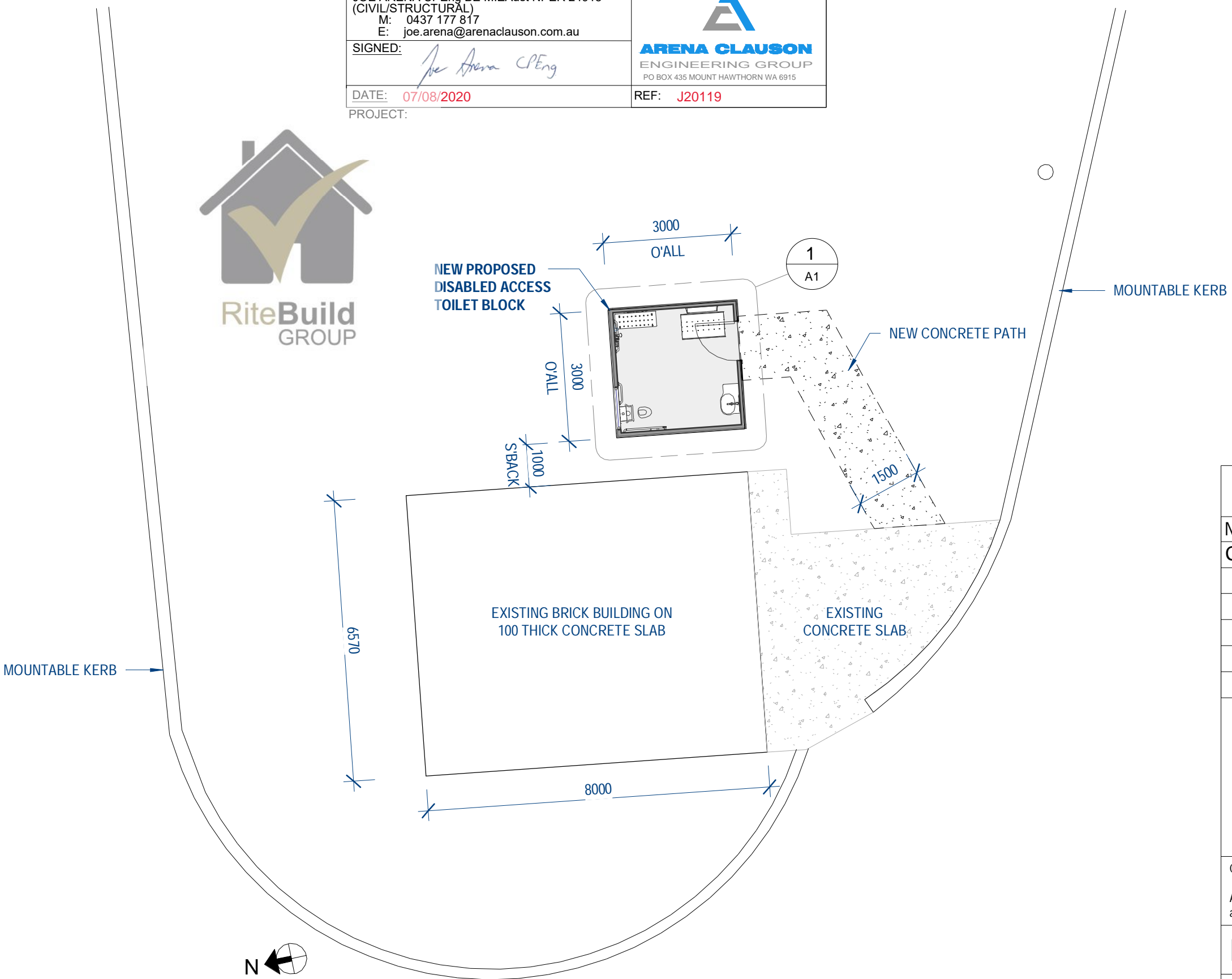

PRELIMINARY DESIGN

NO.	DESCRIPTION	DATE
C	ISSUED FOR REVIEW	06/07/2020



Copyright © 2020 Holtro Modular Pty Ltd
 All rights reserved. No part of this design may be reproduced or used in any matter without written permission of the copyright owner.

DISABLED TOILET BLOCK

MERREDIN TOURIST PARK

SITE PLAN
 SCALE (A3) 1 : 100
 DRAWN CW
 A2
 C

Telephone: 0420 777 542
 e-mail: troy@holtro.com.au
 ABN: 85 634 505 169
 BRN: 103165

Site Layout
 1 : 100

SITE CLASSIFICATION
 1/. SOIL CLASS 'S' IN ACCORDANCE TO AS2870
 2/. WIND CLASS 'N2' IN ACCORDANCE WITH AS4055
 - REGION A,, TC2, T0, NS

NOTES:
 REFER TO 'SITE PLAN - LOCATION MAP' DRAWING BY WAYNES DESIGN & DRAFTING FOR FURTHER SITE INFORMATION

STRUCTURAL CERTIFICATION BY:
 JOE ARENA CPEng BE MIEAust NPER 24918
 (CIVIL/STRUCTURAL)
 M: 0437 177 817
 E: joe.arena@arenaclauson.com.au



SIGNED: *Joe Arena CPEng*

DATE: 07/08/2020

REF: J20119

PROJECT:

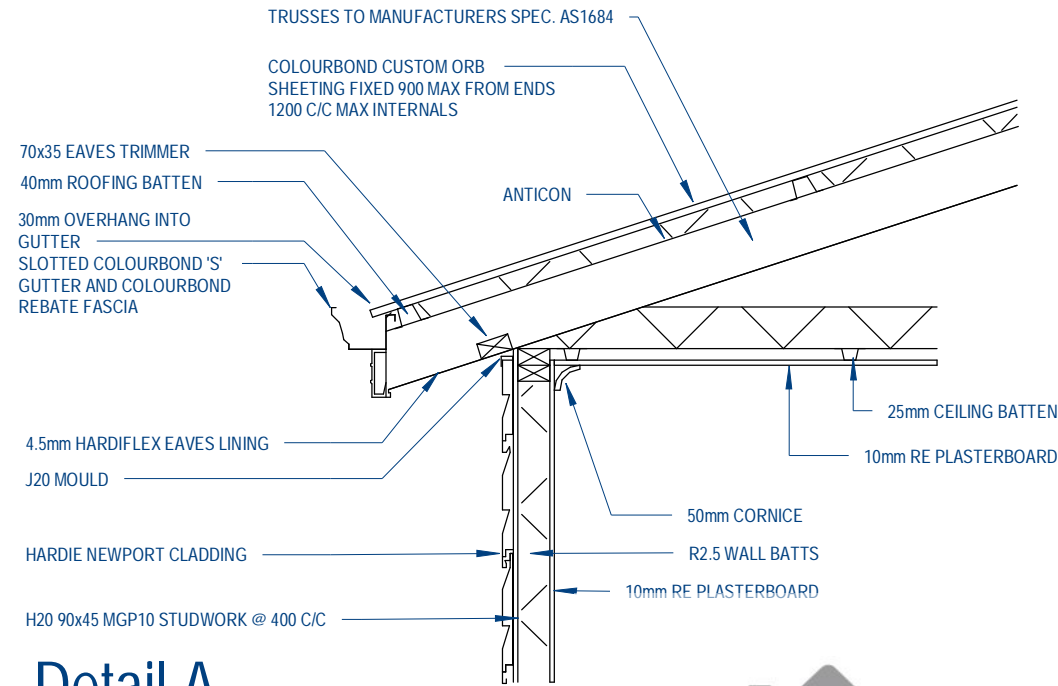

Detail A
1 : 20

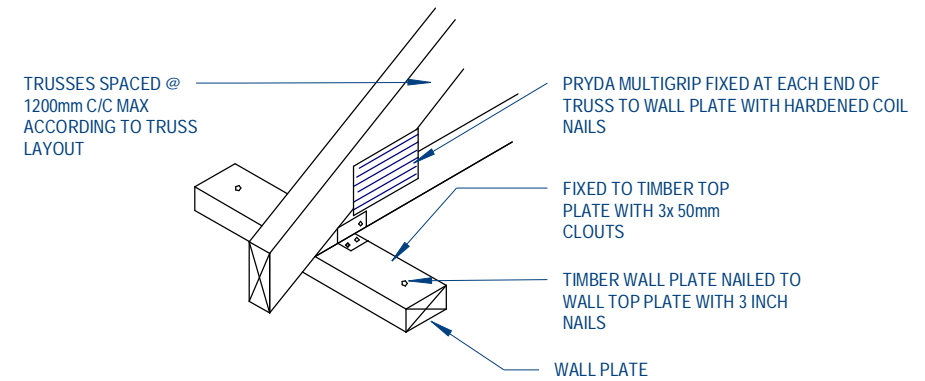

Truss Connection Detail
1 : 20

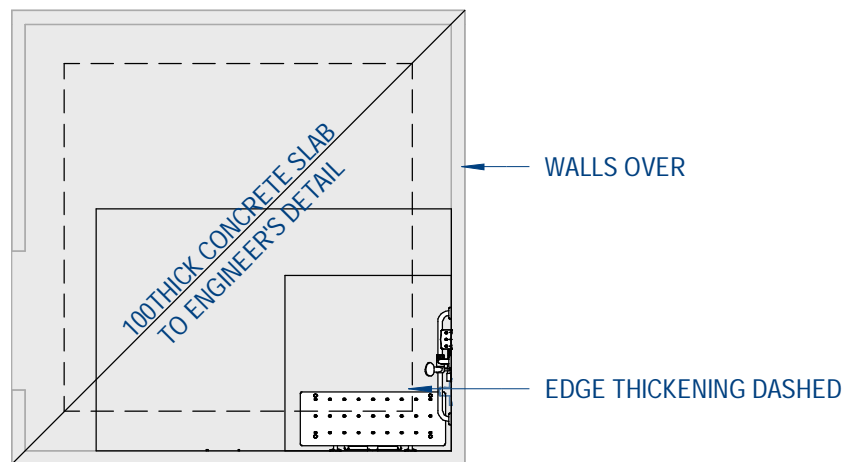

Slab Layout
1 : 50

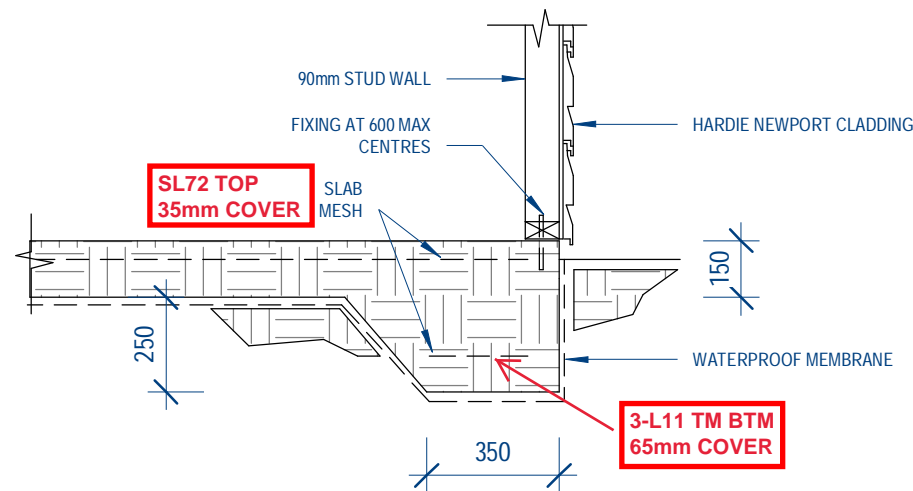

Detail B
1 : 20

PRELIMINARY DESIGN

NO.	DESCRIPTION	DATE
C	ISSUED FOR REVIEW	06/07/2020



Copyright © 2020 Holtro Modular Pty Ltd

All rights reserved. No part of this design may be reproduced or used in any matter without written permission of the copyright owner.

DISABLED TOILET BLOCK

MERREDIN TOURIST PARK

DETAILS AND SLAB LAYOUT

SCALE (A3)
As indicated

DRAWN
CW

A3
C

Telephone: 0420 777 542
e-mail: troy@holtro.com.au

ABN: 85 634 505 169
BRN: 103165

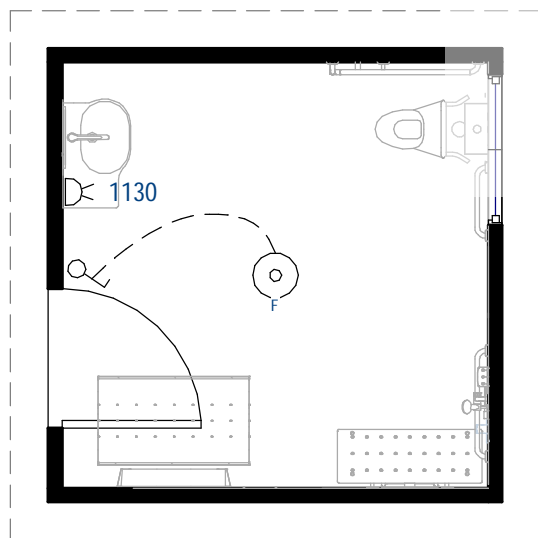

Electrical Plan
1 : 50

ELECTRICAL LEGEND

- ⊙ LIGHT, LED SURFACE MOUNTED
- ⊙_F EXHAUST FAN WITH LED LIGHT
- ⊗_F EXHAUST FAN
- ⊖ EXTERNAL LIGHT, WEATHERPROOF
- ⊖_{SD} SMOKE DETECTOR
- ⌚ GPO 2 GANG, 10A, SINGLE POLE
- ⌚_U GPO 2 GANG, 10A, USB, SINGLE POLE
- TV □ TELEVISION POINT
- ⌚₂ DOUBLE SWITCH
- ⌚₁ SINGLE SWITCH

PRELIMINARY DESIGN

NO.	DESCRIPTION	DATE
C	ISSUED FOR REVIEW	06/07/2020



Copyright © 2020 Holtro Modular Pty Ltd
 All rights reserved. No part of this design may be reproduced or used in any matter without written permission of the copyright owner.

DISABLED TOILET BLOCK

MERREDIN TOURIST PARK

ELECTRICAL PLAN
 SCALE (A3) As indicated DRAWN CW **A5**
 C

Telephone: 0420 777 542 ABN: 85 634 505 169
 e-mail: troy@holtro.com.au BRN: 103165